

FLOJET

"Quad II Diaphragm" 4125 Series Bilge Pump

Model 4125 Series

FEATURES

- Self-Priming
- Dry Running
- Soft, Noise Absorbing Mounts
- 300 Gallons Per Hour
- Corrosion Resistant Materials
- Models Meet U.S.C.G. Electric Standards

SPECIFICATIONS

Motor: Permanent Magnet, Ball Bearings on both Front and Rear Endbells. CE Models are fully suppressed.

Pump: Four chamber diaphragm positive displacement design; Self-priming up to 6 ft. suction lift; Pump able to run dry without damage; Removable port to hose connectors.

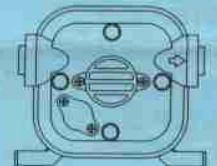
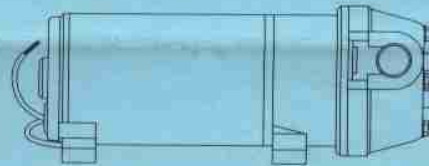
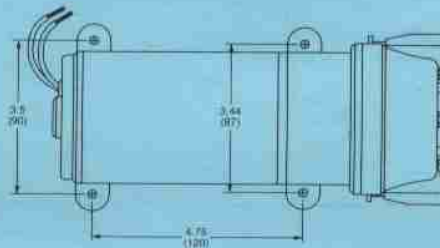

CE

(Available on 12 & 24V d.c. Models)

Pump Series	Dimensions - Inches (mm)			Weight lb. (kg)
	Height	Width	Length	
4125-XXX	3.75 (95)	6.3 (160)	9.2 (234)	6.0 (2.8)

MODEL*	VOLTS	AMP DRAW		FLOW	
		@ 10 psi (0.7 bar)		GPM (l/min)	
4125-114	12V dc	8.5		5.0 (18.9)	
4125-314	24V dc	3.6		5.0 (18.9)	
4125-343	32V dc	2.8		5.0 (18.9)	

* CE fully suppressed models are identified by a prefix "R" and a CE mark on the label. (i.e. R4125-314). Self Declaration Of Conformance (SDOC) is available upon request.

OPERATION

Your "Quad II" pump is designed to self-prime up to 6 feet suction lift (vertical distance from bilge pick-up to pump inlet). The maximum recommended discharge head (distance outlet is above pump) is 15 feet. It is

recommended you utilize an automatic on-off switch so that the pump is turned off when not in use. The "Quad II" is able to run dry (no liquid) for extended periods, however, this could cause needless battery drain.

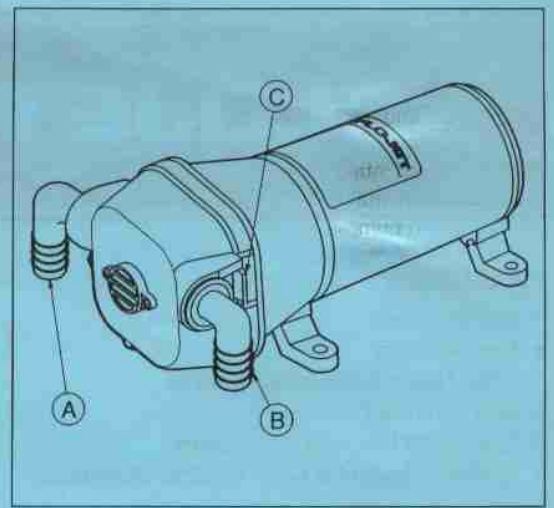
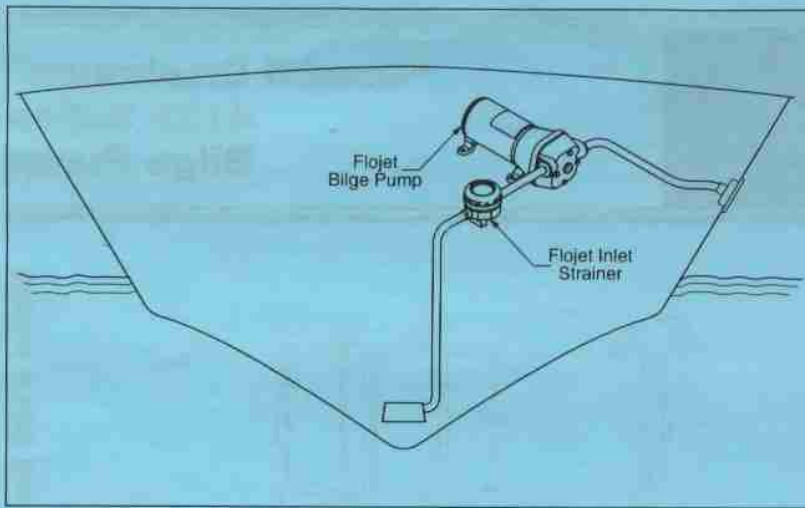

INSTALLATION

STEP 1

Remove shipping plugs from Quad pump ports. Some water from factory testing may spill out.

STEP 2

Install inlet A and discharge B port connectors. Slide clips toward rear, install ports and firmly push slide clips C forward to lock port connectors in place.

STEP 3

Slide rubber mounts fully into 4 mounting tracks.

STEP 4

Mount pump vertically, with pump head down or horizontally in an accessible location (pump is not submersible). If mounting vertically, motor up, attach motor mounts first, then pump head mounts, while

supporting weight of pump.

STEP 5

Use 3/4" I.D. flexible hose (preferably braided or reinforced). Use hose clamps on the slip-on barb hose connections. Use of reinforced vinyl hose is recommended.

STEP 6

Install a Flojet #01610-000 strainer in an accessible location (for inspection and cleaning) between the bilge pick up and pump inlet. This strainer or equivalent is **required** for pump warranty to be valid.

STEP 7

Installation of a screen on the bilge pick up will require less strainer cleaning.

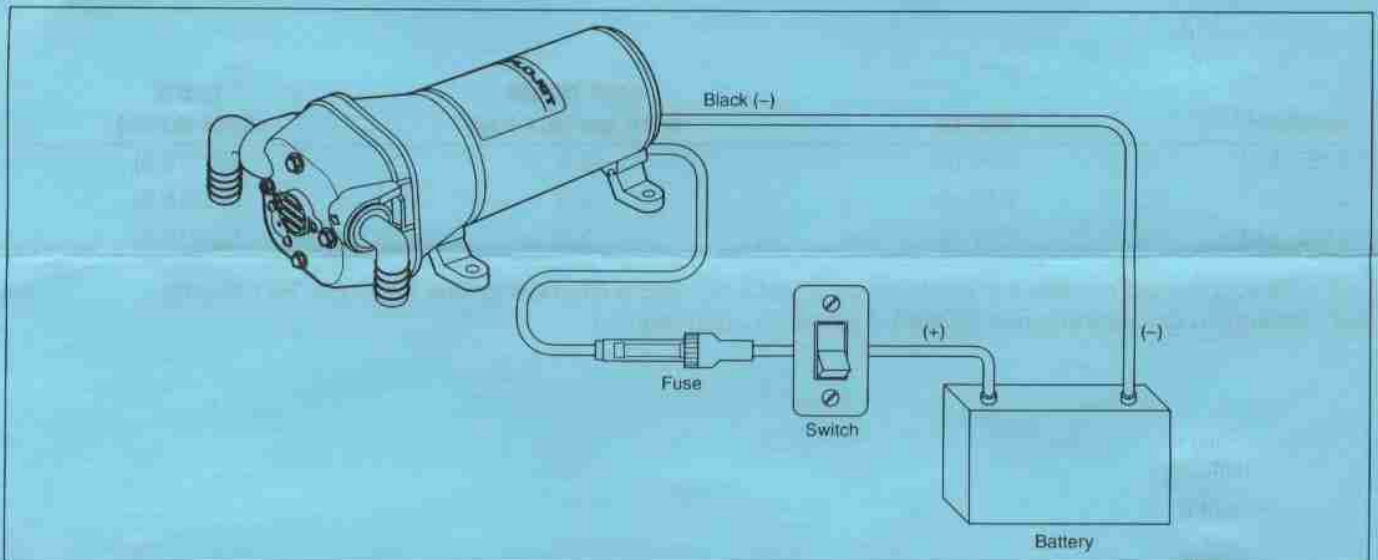

WIRING

STEP 1

Use 14 gauge stranded wire to 20', 12 gauge to 50', from power source.

STEP 2

Use a 15 amp rated on-off switch on the (+) positive (red) motor lead.

STEP 3

Install 15 amp fuse protection on the switched (+) positive lead for 12 volt -114 model; use 10 amp fuse on 24 volt -314 model; and 5 amp fuse on 32 volt -414 model.

TROUBLESHOOTING

WARNING: BEFORE SERVICING PUMP, TURN OFF PUMP AND DRAIN WATER FROM SYSTEM!!

Failure to Prime - Motor operates, but no pump discharge

- Check and clean inlet strainer (make sure bilge pick up is clear)
- Restricted intake or discharge line
- Air leak in intake line
- Debris in pump
- Punctured pump diaphragm (pump leaks)
- Crack in pump housing

Motor falls to turn on

- Loose wiring connection
- Pump circuit has no power
- Blown fuse
- If motor has power **and still won't** turn, either the motor has failed or there is mechanical failure in the lower housing
- Check D.C. voltage at the motor.

Low Flow and Pressure

- Air leak at pump intake
- Accumulation of debris inside pump and plumbing
- Worn pump bearing (excessive noise)
- Punctured pump diaphragm (pump leaks)
- Defective motor
- Inspect check valves (item 2) for debris

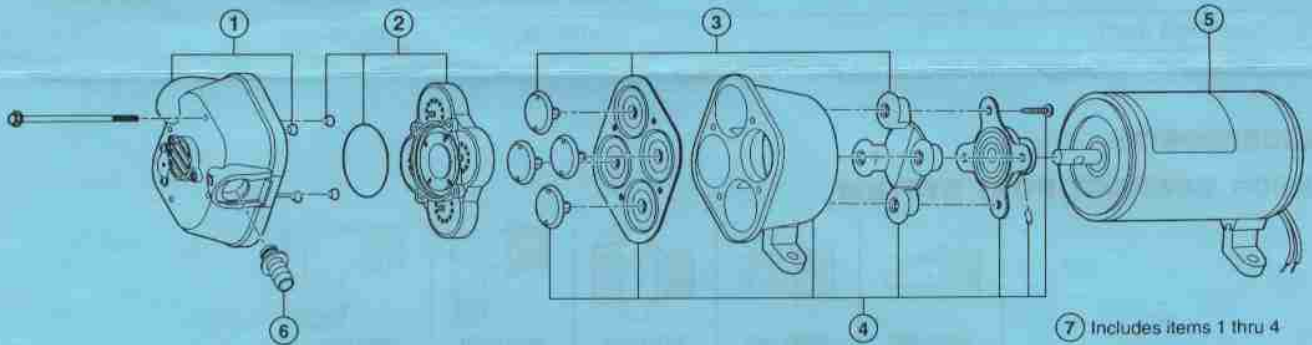

Quite often when a pump is worn or defective the one failed component has overburdened others. To avoid frequent aggravating repairs, Flojet offers service kit assemblies making repairs as quick and easy as possible.

DISASSEMBLE

Upper Housing

1. Loosen but do not remove four pump head screws and carefully remove upper housing assembly (1)
2. Inspect check valve (2) for debris
3. Reassemble new upper housing (1)

Check Valve Assembly

Follow step 1

3. Replace check valve (2)
4. Reassemble upper housing (1)

Lower Housing, Diaphragm, Motor

Follow step 1

3. Rotate lower housing (4) so mounting notch opening on lower housing exposes set screw which holds bearing housing to shaft.
4. Loosen this setscrew by inserting wrench 1/8" Allen wrench into mounting notch opening. Then, slide lower housing (4) off motor shaft.

Diaphragm Cont'd

5. Loosen four cam piston screws with Phillips head screw driver and pull apart cam from inner pistons. (Pistons should always be replaced when a new diaphragm is installed.)

Motor Cont'd

5. Replace Motor

REASSEMBLE

Motor

1. Reassemble lower housing assembly (4) to motor. (Follow steps 4 to 10.)

Diaphragm

2. Lower housing is assembled with:
 - Flat side of diaphragm and outer pistons facing motor
 - Hex stem of inner pistons must be aligned into hex holes in outer pistons (4).
 - Outer pistons must be aligned with alignment slots on cam assembly making sure screw holes align in cam assembly, otherwise diaphragm will leak
3. Tighten cam piston screws partially, center piston in diaphragm, then tighten screws securely (18 in. lbs. torque)

Lower Housing

4. Reassemble lower housing assembly (4) to motor.
5. Retighten set screw securely. Set screw head must be positioned facing motor covering seam (indentation). (Positioning of this screw is critical to avoid misalignment and subsequent diaphragm damage.)

Upper Housing Check Valve

6. Reassemble upper housing (1)
7. Properly seat O-Ring in check valve assembly (2) and check if ferrules and screen are in place on upper housing (1)
8. Install check valve (2) into upper housing (1) and push in.
9. Assemble on to lower housing (4), align 4 screws on to motor by rotating lower housing (4) if necessary to align feet
10. Tighten screws evenly to 30 in. lbs. torque.

BILGE PUMP SERVICE PARTS

KEY#	DESCRIPTION	MODEL#		
		4125-114	4125-314	4125-414
0	Service Kit*	20409-054	20409-054	20409-054
1	Upper Housing With Clips	20404-005	20404-005	20404-005
2	Check Valve Assembly	20407-010	20407-010	20407-010
3	Diaphragm Assembly (includes screws)	20403-050	20403-050	20403-050
4	Lower Housing Assembly	20419-003	20419-003	20419-003
5	Motors	2009-080A	2019-027A	2019-026A
	Motors CE Models	R2009-080A	R2019-027A	—
6	Ports - 3/4 Barb (pair)	20381-012	20381-012	20381-012
	Ports - 3/4 Garden Hose (pair)	20381-013	20381-013	20381-013
7	Pump Head Assembly	20406-005A	20406-005A	20406-005A
8	Side Clips (pair)	20408-000	20408-000	20408-000

*Service Kit includes #2, #3, #8 and drive cam assembly.

ACCESSORIES

QUICK CONNECT PORT SYSTEM

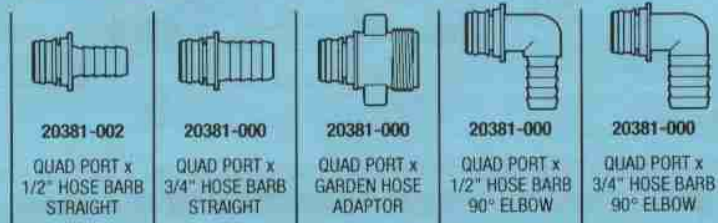

The above part numbers are packaged with 2 fittings per bag.

STRAINERS

Pump Series	Strainer Number	Inlet	Outlet	Screen
4125-XXX	1740-000	3/4 Barb	3/4 Barb	40 Mesh
	1740-101	3/4 Barb	Quad Plug-in	40 Mesh

WARRANTY

FLOJET warrants this product to be free of defects in material and/or workmanship for a period of one year after purchase by the customer from FLOJET. During this one year warranty period, FLOJET will at its option, at no charge to the customer, repair or replace this product if found defective, with a new or reconditioned product, but not to include costs of removal or installation. No product will be accepted for return without a return material authorization number. All return goods must be shipped with transportation charges prepaid. This is only a summary of our Limited Warranty. For a copy of our complete warranty, please request Form No. 100-101.

RETURN PROCEDURE

Prior to returning any product to FLOJET, call customer service for an authorization number. This number must be written on the outside of the shipping package. Place a note inside the package with an explanation regarding the reason for return as well as the authorization number. Include your name, address and phone number.

Flojet



ITT Industries
Engineered for life

U.S.A. Flojet 20 Icon Foothill Ranch, CA 92610-3000 Tel: (949) 859-4945 Fax: (949) 859-1153	UNITED KINGDOM Flojet, Unit 1, Avant Business Centre Denbigh West Industrial Estate Milton Keynes, Bucks, England MK1 1DL Tel: 44 1908 370088 Fax: 44 1908 373731	CANADA Fluid Products Canada 55 Royal Road Guelph, Ontario N1H 1T1 Tel: (519) 821-1900 Fax: (519) 821-2569	JAPAN NHK Jabsco Company Ltd. 3-21-10, Shin-Yokohama Kohoku-Ku, Yokohama, 222 Tel: 045-475-8906 Fax: 045-475-8908	GERMANY Jabsco GmbH Oststrasse 28 22844 Norderstedt Tel: +49-40-53 53 73-0 Fax: +49-40-53 53 73-11
--	--	---	--	---